

How To Repair Diaphragm on Flush Valve

While we were told it was good to drive around with a tiger in our tanks, we cannot speak so highly of the lion in our toilet! The roaring ferocity of a torn flushometer diaphragm can be nerve-racking. Here's how the beast malfunctions: you trip the handle; the diaphragm rises inside the valve, roars, and then snaps closed before enough water has passed through. The only way you can get a full flush is to hold the handle until the job is done. And that's a pain. So read on.

Utensils

Smooth or flat-jaw adjustable wrench
Roll of masking tape
Medium flat blade screwdriver
Adjustable pliers

Ingredients

Diaphragm Flushometer Kit (Copy the brand name on the flushometer and take with you to the hardware store so you are certain of getting the proper kit)
Petroleum jelly

Approximate Time: 30 To 45 Minutes

1. Shut off water supply at stop valve or at main cutoff in basement (Fig. 83A).
2. Tape jaws of wrench or large cap to prevent damage to fixtures.
3. Place wrench on large cap of cover assembly, and turn in counterclockwise direction until assembly is removed (Fig. 83A).
4. Place fingers inside flush valve and find diaphragm. Vulcanized into it is a brass fitting held in place by several rings. This is called the diaphragm operating assembly (Fig. 83B).
5. Remove assembly.
6. Examine diaphragm for holes or tears.
7. Unscrew diaphragm bushing from seat guide in counterclockwise direction.
8. Remove diaphragm and replace with new one, making sure that the strainer side of the bleeder valve is next to seat guide holder. See Figure 83B.
9. Reassemble into flush valve as follows:
 - a. Place seat guide downward into valve.
 - b. Place auxiliary valve seat in center.

10. Replace cover assembly, first lubricating threads with petroleum jelly. Tighten slowly.
11. Turn on water and test.
12. After procedure is completed, it may be necessary to adjust the length of the flush as follows:
 - a. Remove cap nut.
 - b. Insert screwdriver through top of valve seat assembly and turn in a clockwise and counterclockwise direction until proper flush is achieved. Clockwise turning shortens the flush and counterclockwise turning lengthens the flush.
 - c. Replace cap nut.
 - d. Test flush.

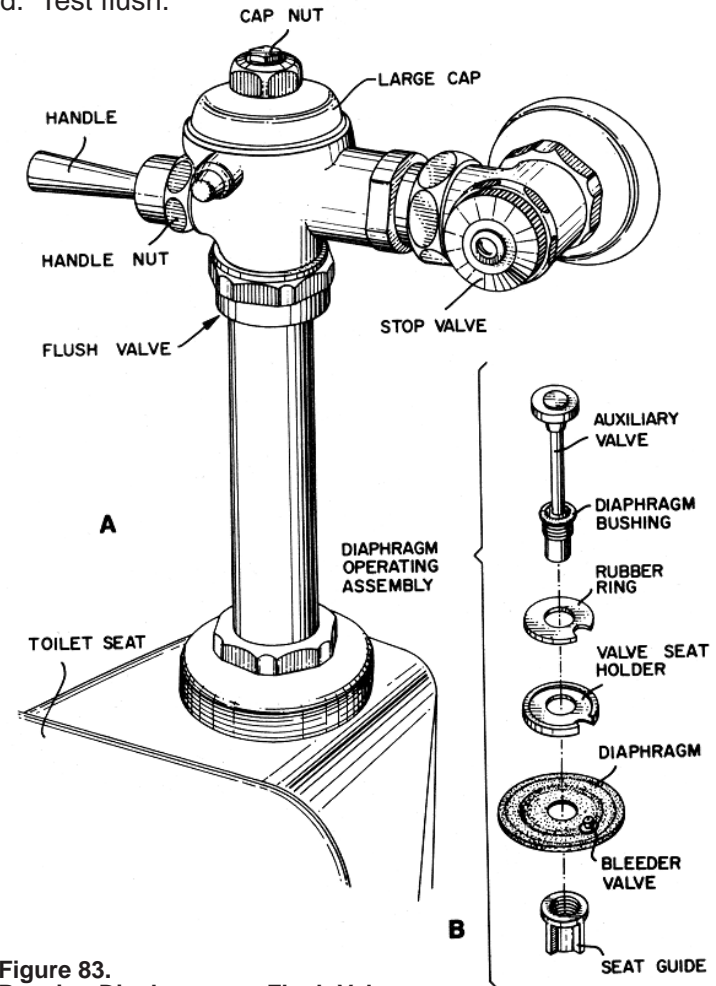

Figure 83.
Repair a Diaphragm on Flush Valve